

### Product Details

range name	GB SMOOTH   GB SANDSTONE SMOOTH
finish	SMOOTH
colours	PORCELAIN   NICKEL   PEWTER   LIMESTONE   PEBBLE
product code   description	10.01   STANDARD

### Properties and Specifications

nominal dimensions (length x width x height mm)	400 × 100 × 200mm
actual dimensions (length x width x height mm)	390 × 90 × 190mm
core volume (% overall thickness)	<30
characteristic unconfined compressive strength (MPa)	>15
minimum shell thickness (mm)	25
average weight (KG)	11
units per tonne	90
number per pallet	180
number per sqm/lm	12.5
durability class (to AS4456.10 - sodium sulphate and sodium chloride)	Exposure Grade
wall mass inc mortar hollow	150
wall mass inc grouted solid	-
Light Reflectance Value	-

### Diagram

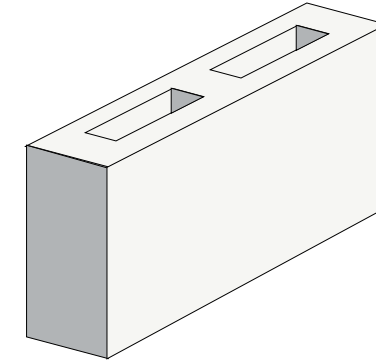

### Fire Resistance Levels^

structural adequacy (see notes)	60 to 240
integrity	60
insulation	60

### Notes

Maximum slenderness ratio (srf) unreinforced masonry from AS3700:2018 Table 6.1 is:

18.0 at 60 minutes | 17.0 at 90 minutes

16.0 at 120 minutes | 15.5 at 180 minutes | 15.5 at 240 minutes

This data represents average results from production lots based on the results achieved by samples selected at random for testing. Figures are accurate at date of publication and subject to change without notice. Contact us for confirmation of product specification. Tested as per AS/NZS 4455.1:2008 and 4456:2003. Fire resistance levels as per AS3700:2018. Acoustic opinion derived from Day Design Pty Ltd. 2012. Tested in accordance with AS 1191:1001 and AS/NZS 1276.1:1999.

^When reinforced and Srf <36: 240 minutes

## Product Details

range name	GB SMOOTH   GB SANDSTONE SMOOTH
finish	SMOOTH
colours	PORCELAIN   NICKEL   PEWTER   LIMESTONE   PEBBLE
product code   description	10.02   THREE QUARTER

## Properties and Specifications

nominal dimensions (length x width x height mm)	300 × 100 × 200mm
actual dimensions (length x width x height mm)	290 × 90 × 190mm
core volume (% overall thickness)	<30
characteristic unconfined compressive strength (MPa)	-
minimum shell thickness (mm)	-
average weight (KG)	7.5
units per tonne	133
number per pallet	240
number per sqm/lm	-
durability class (to AS4456.10 - sodium sulphate and sodium chloride)	Exposure Grade
wall mass inc mortar hollow	-
wall mass inc grouted solid	-
Light Reflectance Value	-

## Diagram

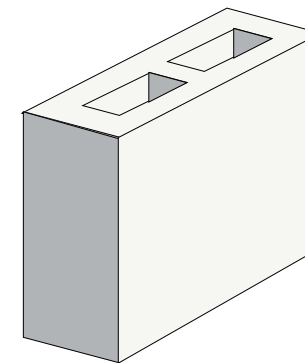

## Fire Resistance Levels^

structural adequacy (see notes)	60 to 240
integrity	60
insulation	60

## Notes

Maximum slenderness ratio (srf) unreinforced masonry from AS3700:2018 Table 6.1 is:

18.0 at 60 minutes | 17.0 at 90 minutes

16.0 at 120 minutes | 15.5 at 180 minutes | 15.5 at 240 minutes

This data represents average results from production lots based on the results achieved by samples selected at random for testing. Figures are accurate at date of publication and subject to change without notice. Contact us for confirmation of product specification. Tested as per AS/NZS 4455.1:2008 and 4456:2003. Fire resistance levels as per AS3700:2018. Acoustic opinion derived from Day Design Pty Ltd. 2012. Tested in accordance with AS 1191:1001 and AS/NZS 1276.1:1999.

^When reinforced and Srf <36: 240 minutes

### Product Details

range name	GB SMOOTH   GB SANDSTONE SMOOTH
finish	SMOOTH
colours	PORCELAIN   NICKEL   PEWTER   LIMESTONE   PEBBLE
product code   description	10.03   HALF

### Properties and Specifications

nominal dimensions (length x width x height mm)	200 × 100 × 200mm
actual dimensions (length x width x height mm)	190 × 90 × 190mm
core volume (% overall thickness)	<30
characteristic unconfined compressive strength (MPa)	>15
minimum shell thickness (mm)	30
average weight (KG)	4.9
units per tonne	204
number per pallet	360
number per sqm/lm	25
durability class (to AS4456.10 - sodium sulphate and sodium chloride)	Exposure Grade
wall mass inc mortar hollow	-
wall mass inc grouted solid	-
Light Reflectance Value	-

### Diagram

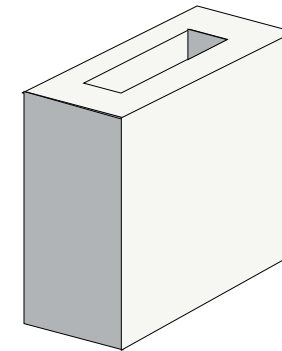

### Fire Resistance Levels^

structural adequacy (see notes)	60 to 240
integrity	60
insulation	60

### Notes

Maximum slenderness ratio (srf) unreinforced masonry from AS3700:2018 Table 6.1 is:

18.0 at 60 minutes | 17.0 at 90 minutes

16.0 at 120 minutes | 15.5 at 180 minutes | 15.5 at 240 minutes

This data represents average results from production lots based on the results achieved by samples selected at random for testing. Figures are accurate at date of publication and subject to change without notice. Contact us for confirmation of product specification. Tested as per AS/NZS 4455.1:2008 and 4456:2003. Fire resistance levels as per AS3700:2018. Acoustic opinion derived from Day Design Pty Ltd. 2012. Tested in accordance with AS 1191:1001 and AS/NZS 1276.1:1999.

^When reinforced and Srf <36: 240 minutes

## Product Details

range name	GB SMOOTH   GB SANDSTONE SMOOTH
finish	SMOOTH
colours	PORCELAIN   NICKEL   PEWTER   LIMESTONE   PEBBLE
product code   description	10.25   CORNER RETURN

## Properties and Specifications

nominal dimensions (length x width x height mm)	400 × 100 × 200mm
actual dimensions (length x width x height mm)	390 × 90 × 190mm
core volume (% overall thickness)	<30
characteristic unconfined compressive strength (MPa)	-
minimum shell thickness (mm)	-
average weight (KG)	15.2
units per tonne	65.78
number per pallet	120
number per sqm/lm	-
durability class (to AS4456.10 - sodium sulphate and sodium chloride)	Exposure Grade
wall mass inc mortar hollow	-
wall mass inc grouted solid	-
Light Reflectance Value	-

## Diagram

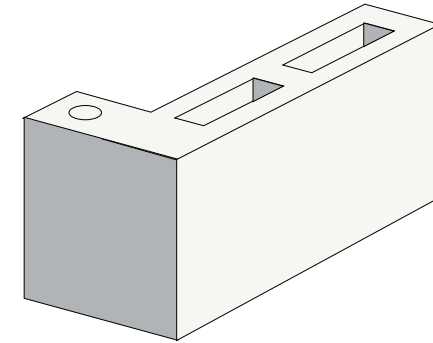

## Fire Resistance Levels^

structural adequacy (see notes)	60 to 240
integrity	60
insulation	60

## Notes

Maximum slenderness ratio (srf) unreinforced masonry from AS3700:2018 Table 6.1 is:

18.0 at 60 minutes | 17.0 at 90 minutes

16.0 at 120 minutes | 15.5 at 180 minutes | 15.5 at 240 minutes

This data represents average results from production lots based on the results achieved by samples selected at random for testing. Figures are accurate at date of publication and subject to change without notice. Contact us for confirmation of product specification. Tested as per AS/NZS 4455.1:2008 and 4456:2003. Fire resistance levels as per AS3700:2018. Acoustic opinion derived from Day Design Pty Ltd. 2012. Tested in accordance with AS 1191:1001 and AS/NZS 1276.1:1999.

^When reinforced and Srf <36: 240 minutes

## Product Details

range name	GB SMOOTH   GB SANDSTONE SMOOTH
finish	SMOOTH
colours	PORCELAIN   NICKEL   PEWTER   LIMESTONE   PEBBLE
product code   description	10.38   HALF HEIGHT SILL

## Properties and Specifications

nominal dimensions (length x width x height mm)	200 x 100 x 140mm
actual dimensions (length x width x height mm)	190 x 90 x 130 x 18mm
core volume (% overall thickness)	<30
characteristic unconfined compressive strength (MPa)	-
minimum shell thickness (mm)	-
average weight (KG)	3.8
units per tonne	263
number per pallet	448
number per sqm/lm	-
durability class (to AS4456.10 - sodium sulphate and sodium chloride)	Exposure Grade
wall mass inc mortar hollow	-
wall mass inc grouted solid	-
Light Reflectance Value	-

## Diagram

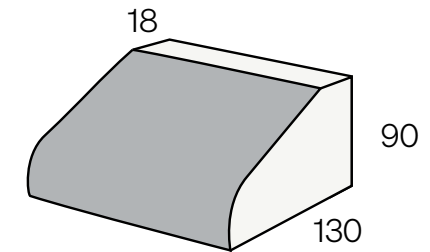

## Fire Resistance Levels^

structural adequacy (see notes)	60 to 240
integrity	60
insulation	60

## Notes

Maximum slenderness ratio (srf) unreinforced masonry from AS3700:2018 Table 6.1 is:

18.0 at 60 minutes | 17.0 at 90 minutes

16.0 at 120 minutes | 15.5 at 180 minutes | 15.5 at 240 minutes

This data represents average results from production lots based on the results achieved by samples selected at random for testing. Figures are accurate at date of publication and subject to change without notice. Contact us for confirmation of product specification. Tested as per AS/NZS 4455.1:2008 and 4456:2003. Fire resistance levels as per AS3700:2018. Acoustic opinion derived from Day Design Pty Ltd. 2012. Tested in accordance with AS 1191:1001 and AS/NZS 1276.1:1999.

^When reinforced and Srf <36: 240 minutes

## Product Details

range name	GB SMOOTH   GB SANDSTONE SMOOTH
finish	SMOOTH
colours	PORCELAIN   NICKEL   PEWTER   LIMESTONE   PEBBLE
product code   description	10.71   STANDARD HALF HEIGHT

## Properties and Specifications

nominal dimensions (length x width x height mm)	400 × 100 × 100mm
actual dimensions (length x width x height mm)	390 × 90 × 90mm
core volume (% overall thickness)	28
characteristic unconfined compressive strength (MPa)	>15
minimum shell thickness (mm)	25
average weight (KG)	5.3
units per tonne	189
number per pallet	360
number per sqm/lm	25 or 2.5 per LM
durability class (to AS4456.10 - sodium sulphate and sodium chloride)	Exposure Grade
wall mass inc mortar hollow	147
wall mass inc grouted solid	-
Light Reflectance Value	-

## Diagram

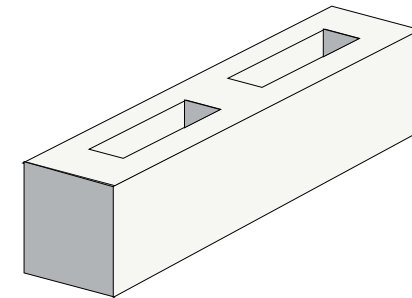

## Fire Resistance Levels^

structural adequacy (see notes)	60 to 240
integrity	60
insulation	60

## Notes

Maximum slenderness ratio (srf) unreinforced masonry from AS3700:2018 Table 6.1 is:

18.0 at 60 minutes | 17.0 at 90 minutes

16.0 at 120 minutes | 15.5 at 180 minutes | 15.5 at 240 minutes

This data represents average results from production lots based on the results achieved by samples selected at random for testing. Figures are accurate at date of publication and subject to change without notice. Contact us for confirmation of product specification. Tested as per AS/NZS 4455.1:2008 and 4456:2003. Fire resistance levels as per AS3700:2018. Acoustic opinion derived from Day Design Pty Ltd. 2012. Tested in accordance with AS 1191:1001 and AS/NZS 1276.1:1999.

^When reinforced and Srf <36: 240 minutes

## Product Details

range name	GB SMOOTH   GB SANDSTONE SMOOTH
finish	SMOOTH
colours	PORCELAIN   NICKEL   PEWTER   LIMESTONE   PEBBLE
product code   description	20.01   190MM STANDARD

## Properties and Specifications

nominal dimensions (length x width x height mm)	400 × 200 × 200mm
actual dimensions (length x width x height mm)	390 × 190 × 190mm
core volume (% overall thickness)	47
characteristic unconfined compressive strength (MPa)	>15
minimum shell thickness (mm)	30
average weight (KG)	15.6
units per tonne	64
number per pallet	90
number per sqm/lm	12.5
durability class (to AS4456.10 - sodium sulphate and sodium chloride)	Exposure Grade
wall mass inc mortar hollow	204
wall mass inc grouted solid	-
Light Reflectance Value	-

## Diagram

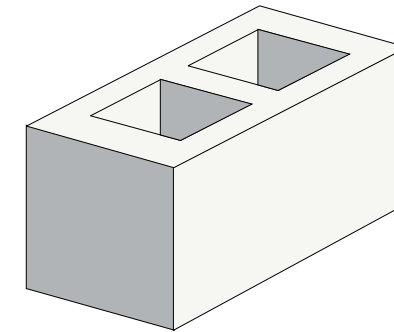

## Fire Resistance Levels^

structural adequacy (see notes)	60 to 240
integrity	60
insulation	60

## Notes

Maximum slenderness ratio (srf) unreinforced masonry from AS3700:2018 Table 6.1 is:

18.0 at 60 minutes | 17.0 at 90 minutes

16.0 at 120 minutes | 15.5 at 180 minutes | 15.5 at 240 minutes

This data represents average results from production lots based on the results achieved by samples selected at random for testing. Figures are accurate at date of publication and subject to change without notice. Contact us for confirmation of product specification. Tested as per AS/NZS 4455.1:2008 and 4456:2003. Fire resistance levels as per AS3700:2018. Acoustic opinion derived from Day Design Pty Ltd. 2012. Tested in accordance with AS 1191:1001 and AS/NZS 1276.1:1999.

^When reinforced and Srf <36: 240 minutes

## Product Details

range name	GB SMOOTH   GB SANDSTONE SMOOTH
finish	SMOOTH
colours	PORCELAIN   NICKEL   PEWTER   LIMESTONE   PEBBLE
product code   description	20.02   190MM THREE QUARTER

## Properties and Specifications

nominal dimensions (length x width x height mm)	300 × 200 × 200mm
actual dimensions (length x width x height mm)	290 × 190 × 190mm
core volume (% overall thickness)	48
characteristic unconfined compressive strength (MPa)	>15
minimum shell thickness (mm)	-
average weight (KG)	14.3
units per tonne	69
number per pallet	90
number per sqm/lm	-
durability class (to AS4456.10 - sodium sulphate and sodium chloride)	Exposure Grade
wall mass inc mortar hollow	-
wall mass inc grouted solid	-
Light Reflectance Value	-

## Diagram

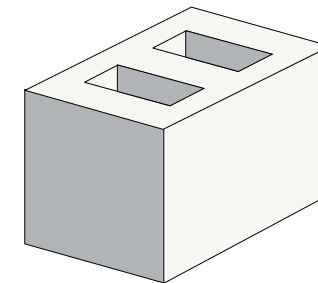

## Fire Resistance Levels^

structural adequacy (see notes)	60 to 240
integrity	60
insulation	60

## Notes

Maximum slenderness ratio (srf) unreinforced masonry from AS3700:2018 Table 6.1 is:

18.0 at 60 minutes | 17.0 at 90 minutes

16.0 at 120 minutes | 15.5 at 180 minutes | 15.5 at 240 minutes

This data represents average results from production lots based on the results achieved by samples selected at random for testing. Figures are accurate at date of publication and subject to change without notice. Contact us for confirmation of product specification. Tested as per AS/NZS 4455.1:2008 and 4456:2003. Fire resistance levels as per AS3700:2018. Acoustic opinion derived from Day Design Pty Ltd. 2012. Tested in accordance with AS 1191:1001 and AS/NZS 1276.1:1999.

^When reinforced and Srf <36: 240 minutes



## Product Details

range name	GB SMOOTH   GB SANDSTONE SMOOTH
finish	SMOOTH
colours	PORCELAIN   NICKEL   PEWTER   LIMESTONE   PEBBLE
product code   description	20.03   190MM HALF

## Properties and Specifications

nominal dimensions (length x width x height mm)	200 × 200 × 200mm
actual dimensions (length x width x height mm)	190 × 190 × 190mm
core volume (% overall thickness)	>30
characteristic unconfined compressive strength (MPa)	>15
minimum shell thickness (mm)	30
average weight (KG)	8.7
units per tonne	115
number per pallet	180
number per sqm/lm	25
durability class (to AS4456.10 - sodium sulphate and sodium chloride)	Exposure Grade
wall mass inc mortar hollow	-
wall mass inc grouted solid	-
Light Reflectance Value	-

## Diagram

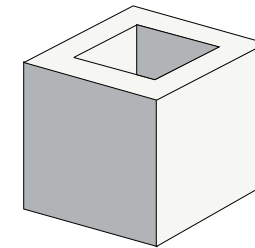

## Fire Resistance Levels^

structural adequacy (see notes)	60 to 240
integrity	60
insulation	60

## Notes

Maximum slenderness ratio (srf) unreinforced masonry from AS3700:2018 Table 6.1 is:

18.0 at 60 minutes | 17.0 at 90 minutes

16.0 at 120 minutes | 15.5 at 180 minutes | 15.5 at 240 minutes

This data represents average results from production lots based on the results achieved by samples selected at random for testing. Figures are accurate at date of publication and subject to change without notice. Contact us for confirmation of product specification. Tested as per AS/NZS 4455.1:2008 and 4456:2003. Fire resistance levels as per AS3700:2018. Acoustic opinion derived from Day Design Pty Ltd. 2012. Tested in accordance with AS 1191:1001 and AS/NZS 1276.1:1999.

^When reinforced and Srf <36: 240 minutes

### Product Details

range name	GB SMOOTH   GB SANDSTONE SMOOTH
finish	SMOOTH
colours	PORCELAIN   NICKEL   PEWTER   LIMESTONE   PEBBLE
product code   description	20.13   HALF LINTEL

### Properties and Specifications

nominal dimensions (length x width x height mm)	200 × 200 × 200mm
actual dimensions (length x width x height mm)	190 × 190 × 190mm
core volume (% overall thickness)	>30
characteristic unconfined compressive strength (MPa)	-
minimum shell thickness (mm)	-
average weight (KG)	16.7
units per tonne	59
number per pallet	180
number per sqm/lm	-
durability class (to AS4456.10 - sodium sulphate and sodium chloride)	Exposure Grade
wall mass inc mortar hollow	-
wall mass inc grouted solid	-
Light Reflectance Value	-

### Diagram

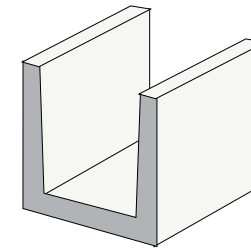

### Fire Resistance Levels^

structural adequacy (see notes)	60 to 240
integrity	60
insulation	60

### Notes

Maximum slenderness ratio (srf) unreinforced masonry from AS3700:2018 Table 6.1 is:

18.0 at 60 minutes | 17.0 at 90 minutes

16.0 at 120 minutes | 15.5 at 180 minutes | 15.5 at 240 minutes

This data represents average results from production lots based on the results achieved by samples selected at random for testing. Figures are accurate at date of publication and subject to change without notice. Contact us for confirmation of product specification. Tested as per AS/NZS 4455.1: 2008 and 4456: 2003. Fire resistance levels as per AS3700: 2018. Acoustic opinion derived from Day Design Pty Ltd. 2012. Tested in accordance with AS 1191:1001 and AS/NZS 1276.1:1999.

^When reinforced and Srf <36: 240 minutes

## Product Details

range name	GB SMOOTH   GB SANDSTONE SMOOTH
finish	SMOOTH
colours	PORCELAIN   NICKEL   PEWTER   LIMESTONE   PEBBLE
product code   description	20.20   KNOCKOUT

## Properties and Specifications

nominal dimensions (length x width x height mm)	400 × 200 × 200mm
actual dimensions (length x width x height mm)	390 × 190 × 190mm
core volume (% overall thickness)	53
characteristic unconfined compressive strength (MPa)	>15
minimum shell thickness (mm)	30
average weight (KG)	12.7
units per tonne	79
number per pallet	90
number per sqm/lm	2.5 PER LM
durability class (to AS4456.10 - sodium sulphate and sodium chloride)	Exposure Grade
wall mass inc mortar hollow	168
wall mass inc grouted solid	-
Light Reflectance Value	-

## Diagram

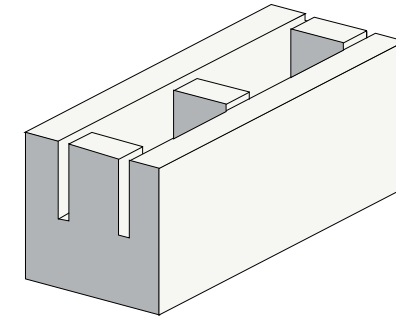

## Fire Resistance Levels^

structural adequacy (see notes)	60 to 240
integrity	60
insulation	60

## Notes

Maximum slenderness ratio (srf) unreinforced masonry from AS3700:2018 Table 6.1 is:

18.0 at 60 minutes | 17.0 at 90 minutes

16.0 at 120 minutes | 15.5 at 180 minutes | 15.5 at 240 minutes

This data represents average results from production lots based on the results achieved by samples selected at random for testing. Figures are accurate at date of publication and subject to change without notice. Contact us for confirmation of product specification. Tested as per AS/NZS 4455.1:2008 and 4456:2003. Fire resistance levels as per AS3700:2018. Acoustic opinion derived from Day Design Pty Ltd. 2012. Tested in accordance with AS 1191:1001 and AS/NZS 1276.1:1999.

^When reinforced and Srf <36: 240 minutes

## Product Details

range name	GB SMOOTH   GB SANDSTONE SMOOTH
finish	SMOOTH
colours	PORCELAIN   NICKEL   PEWTER   LIMESTONE   PEBBLE
product code   description	20.25   THREE QUARTER LINTEL

## Properties and Specifications

nominal dimensions (length x width x height mm)	300 × 200 × 200mm
actual dimensions (length x width x height mm)	290 × 190 × 190mm
core volume (% overall thickness)	30
characteristic unconfined compressive strength (MPa)	-
minimum shell thickness (mm)	-
average weight (KG)	14.3
units per tonne	69
number per pallet	120
number per sqm/lm	-
durability class (to AS4456.10 - sodium sulphate and sodium chloride)	Exposure Grade
wall mass inc mortar hollow	-
wall mass inc grouted solid	-
Light Reflectance Value	-

## Diagram

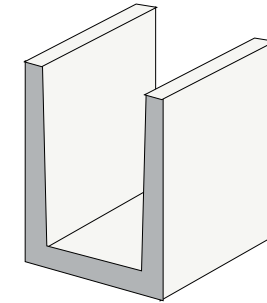

## Fire Resistance Levels^

structural adequacy (see notes)	60 to 240
integrity	60
insulation	60

## Notes

Maximum slenderness ratio (srf) unreinforced masonry from AS3700:2018 Table 6.1 is:

18.0 at 60 minutes | 17.0 at 90 minutes

16.0 at 120 minutes | 15.5 at 180 minutes | 15.5 at 240 minutes

This data represents average results from production lots based on the results achieved by samples selected at random for testing. Figures are accurate at date of publication and subject to change without notice. Contact us for confirmation of product specification. Tested as per AS/NZS 4455.1:2008 and 4456:2003. Fire resistance levels as per AS3700:2018. Acoustic opinion derived from Day Design Pty Ltd. 2012. Tested in accordance with AS 1191:1001 and AS/NZS 1276.1:1999.

^When reinforced and Srf <36: 240 minutes

## Product Details

range name	GB SMOOTH   GB SANDSTONE SMOOTH
finish	SMOOTH
colours	PORCELAIN   NICKEL   PEWTER   LIMESTONE   PEBBLE
product code   description	20.38   HALF HEIGHT SILL

## Properties and Specifications

nominal dimensions (length x width x height mm)	245mm x 190 x 100
actual dimensions (length x width x height mm)	245mm x 190 x 100
core volume (% overall thickness)	>30
characteristic unconfined compressive strength (MPa)	-
minimum shell thickness (mm)	-
average weight (KG)	8.3
units per tonne	120
number per pallet	224
number per sqm/lm	-
durability class (to AS4456.10 - sodium sulphate and sodium chloride)	Exposure Grade
wall mass inc mortar hollow	-
wall mass inc grouted solid	-
Light Reflectance Value	-

## Diagram

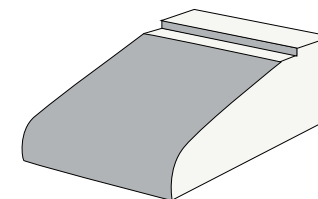

## Fire Resistance Levels^

structural adequacy (see notes)	60 to 240
integrity	60
insulation	60

## Notes

Maximum slenderness ratio (srf) unreinforced masonry from AS3700:2018 Table 6.1 is:

18.0 at 60 minutes | 17.0 at 90 minutes

16.0 at 120 minutes | 15.5 at 180 minutes | 15.5 at 240 minutes

This data represents average results from production lots based on the results achieved by samples selected at random for testing. Figures are accurate at date of publication and subject to change without notice. Contact us for confirmation of product specification. Tested as per AS/NZS 4455.1:2008 and 4456:2003. Fire resistance levels as per AS3700:2018. Acoustic opinion derived from Day Design Pty Ltd. 2012. Tested in accordance with AS 1191:1001 and AS/NZS 1276.1:1999.

^When reinforced and Srf <36: 240 minutes

### Product Details

range name	GB SMOOTH   GB SANDSTONE SMOOTH
finish	SMOOTH
colours	PORCELAIN   NICKEL   PEWTER   LIMESTONE   PEBBLE
product code   description	20.42   190MM CHANNEL

### Properties and Specifications

nominal dimensions (length x width x height mm)	400 × 200 × 200mm
actual dimensions (length x width x height mm)	390 × 190 × 190mm
core volume (% overall thickness)	>30
characteristic unconfined compressive strength (MPa)	>15
minimum shell thickness (mm)	30
average weight (KG)	15
units per tonne	64
number per pallet	90
number per sqm/lm	12.5
durability class (to AS4456.10 - sodium sulphate and sodium chloride)	Exposure Grade
wall mass inc mortar hollow	204
wall mass inc grouted solid	-
Light Reflectance Value	-

### Diagram

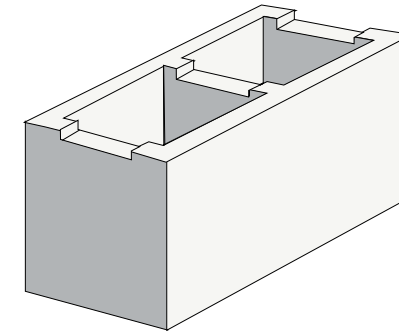

### Fire Resistance Levels^

structural adequacy (see notes)	60 to 240
integrity	60
insulation	60

### Notes

Maximum slenderness ratio (srf) unreinforced masonry from AS3700:2018 Table 6.1 is:

18.0 at 60 minutes | 17.0 at 90 minutes

16.0 at 120 minutes | 15.5 at 180 minutes | 15.5 at 240 minutes

This data represents average results from production lots based on the results achieved by samples selected at random for testing. Figures are accurate at date of publication and subject to change without notice. Contact us for confirmation of product specification. Tested as per AS/NZS 4455.1:2008 and 4456:2003. Fire resistance levels as per AS3700:2018. Acoustic opinion derived from Day Design Pty Ltd. 2012. Tested in accordance with AS 1191:1001 and AS/NZS 1276.1:1999.

^When reinforced and Srf <36: 240 minutes

## Product Details

range name	GB SMOOTH   GB SANDSTONE SMOOTH
finish	SMOOTH
colours	PORCELAIN   NICKEL   PEWTER   LIMESTONE   PEBBLE
product code   description	20.71   STANDARD HALF HEIGHT

## Properties and Specifications

nominal dimensions (length x width x height mm)	400 × 200 × 100mm
actual dimensions (length x width x height mm)	390 × 190 × 90mm
core volume (% overall thickness)	47
characteristic unconfined compressive strength (MPa)	>15
minimum shell thickness (mm)	30
average weight (KG)	8
units per tonne	125
number per pallet	180
number per sqm/lm	25
durability class (to AS4456.10 - sodium sulphate and sodium chloride)	Exposure Grade
wall mass inc mortar hollow	215
wall mass inc grouted solid	-
Light Reflectance Value	-

## Diagram

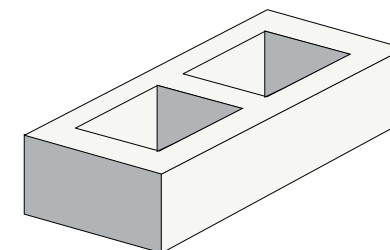

## Fire Resistance Levels^

structural adequacy (see notes)	60 to 240
integrity	60
insulation	60

## Notes

Maximum slenderness ratio (srf) unreinforced masonry from AS3700:2018 Table 6.1 is:

18.0 at 60 minutes | 17.0 at 90 minutes

16.0 at 120 minutes | 15.5 at 180 minutes | 15.5 at 240 minutes

This data represents average results from production lots based on the results achieved by samples selected at random for testing. Figures are accurate at date of publication and subject to change without notice. Contact us for confirmation of product specification. Tested as per AS/NZS 4455.1:2008 and 4456:2003. Fire resistance levels as per AS3700:2018. Acoustic opinion derived from Day Design Pty Ltd. 2012. Tested in accordance with AS 1191:1001 and AS/NZS 1276.1:1999.

^When reinforced and Srf <36: 240 minutes

## Product Details

range name	GB SMOOTH   GB SANDSTONE SMOOTH
finish	SMOOTH
colours	PORCELAIN   NICKEL   PEWTER   LIMESTONE   PEBBLE
product code   description	30.02   THREE QUARTER

## Properties and Specifications

nominal dimensions (length x width x height mm)	300 × 300 × 200mm
actual dimensions (length x width x height mm)	290 × 290 × 190mm
core volume (% overall thickness)	30
characteristic unconfined compressive strength (MPa)	-
minimum shell thickness (mm)	-
average weight (KG)	16.7
units per tonne	59
number per pallet	80
number per sqm/lm	-
durability class (to AS4456.10 - sodium sulphate and sodium chloride)	Exposure Grade
wall mass inc mortar hollow	-
wall mass inc grouted solid	-
Light Reflectance Value	-

## Diagram

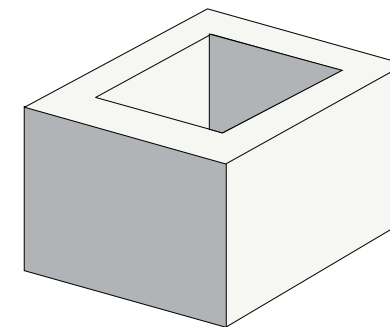

## Fire Resistance Levels^

structural adequacy (see notes)	60 to 240
integrity	60
insulation	60

## Notes

Maximum slenderness ratio (srf) unreinforced masonry from AS3700:2018 Table 6.1 is:

18.0 at 60 minutes | 17.0 at 90 minutes

16.0 at 120 minutes | 15.5 at 180 minutes | 15.5 at 240 minutes

This data represents average results from production lots based on the results achieved by samples selected at random for testing. Figures are accurate at date of publication and subject to change without notice. Contact us for confirmation of product specification. Tested as per AS/NZS 4455.1:2008 and 4456:2003. Fire resistance levels as per AS3700:2018. Acoustic opinion derived from Day Design Pty Ltd. 2012. Tested in accordance with AS 1191:1001 and AS/NZS 1276.1:1999.

^When reinforced and Srf <36: 240 minutes



### Product Details

range name	GB SMOOTH   GB SANDSTONE SMOOTH
finish	SMOOTH
colours	PORCELAIN   NICKEL   PEWTER   LIMESTONE   PEBBLE
product code   description	50.31   CAPPING TILE

### Properties and Specifications

nominal dimensions (length x width x height mm)	400 × 200 × 50mm
actual dimensions (length x width x height mm)	390 × 190 × 40mm
core volume (% overall thickness)	-
characteristic unconfined compressive strength (MPa)	-
minimum shell thickness (mm)	-
average weight (KG)	6.1
units per tonne	163
number per pallet	288
number per sqm/lm	2.5/50
durability class (to AS4456.10 - sodium sulphate and sodium chloride)	Exposure Grade
wall mass inc mortar hollow	-
wall mass inc grouted solid	-
Light Reflectance Value	-

### Diagram

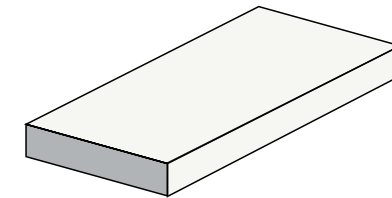

### Fire Resistance Levels^

structural adequacy (see notes)	60 to 240
integrity	60
insulation	60

### Notes

Maximum slenderness ratio (srf) unreinforced masonry from AS3700:2018 Table 6.1 is:

18.0 at 60 minutes | 17.0 at 90 minutes

16.0 at 120 minutes | 15.5 at 180 minutes | 15.5 at 240 minutes

This data represents average results from production lots based on the results achieved by samples selected at random for testing. Figures are accurate at date of publication and subject to change without notice. Contact us for confirmation of product specification. Tested as per AS/NZS 4455.1:2008 and 4456:2003. Fire resistance levels as per AS3700:2018. Acoustic opinion derived from Day Design Pty Ltd. 2012. Tested in accordance with AS 1191:1001 and AS/NZS 1276.1:1999.

^When reinforced and Srf <36: 240 minutes